

**ENABLING HAZARD WARNING LIGHTS TO BE OPERATED IN A WAY THAT DOES NOT INVOLVE THE “STANDARD PULL OUT SWITCH”.**

LED bulbs in the repeaters in an MGB make a huge difference.

The two attached schemes were offered by Duncan of classic car LEDs.

A member used one of these on an MGC (relocating the OD switch to the gearstick and deploying the OD switch position to function as the hazard flasher switch)

**ADDING HAZARDS USING 2 SWITCHING RELAYS**

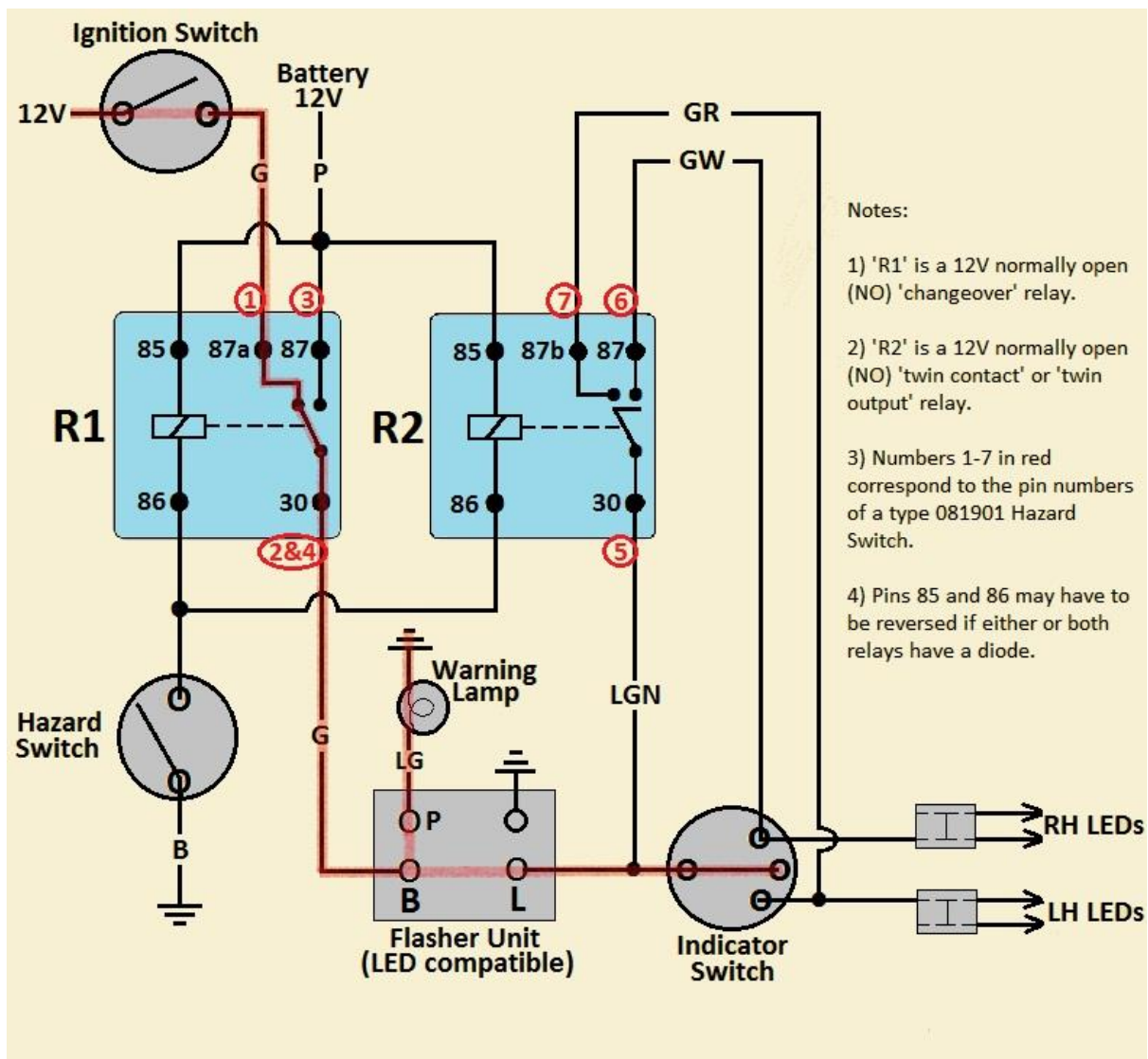

### ADDING HAZARDS USING 3PDT SWITCH

